

**A matter of experience.**

N&W has been developing and producing automatic beverage dispensers for many years and supplies over 100 countries. This market leadership has been achieved and maintained by investing heavily in research and development and is the result of many years of technical and manufacturing experience, combined with a passion for innovation and design.

N&W products are developed and produced using processes approved to two internationally recognised standards, one for quality - UNI EN ISO 9001:2000 - Valbrembo, Mozzo, Odense and Bilston sites, and one for the environment - UNI EN ISO 14001 - Valbrembo and Mozzo sites.

N&W is committed to providing the market with first-class high quality products and the quality certification of all its plants underlines this significant commitment. With regard to the environment, N&W has always paid great attention to the environmental impact of its products and processes and continuously strives to keep this to a minimum.

A further important certification achieved by N&W is supplied by IMQ, Istituto Italiano del Marchio di Qualità (Italian Quality Trademark Institute). This certification assures all N&W products meet the home appliance safety standards as well as the safety standards for commercial dispensers.



N&W GLOBAL VENDING Ltd.  
 P.O. Box 25, Dudley Street  
 Bilston  
 West Midlands WV14 0LF  
 Ph. +44 (0)1902 355 000  
 Fax +44 (0)1902 402 272

[www.nwglobalvending.co.uk](http://www.nwglobalvending.co.uk)

N&W GLOBAL VENDING S.p.A.  
 Via Roma 24 - 24030 Valbrembo (BG) - Italy  
 Ph. +39 035 606 111  
 Fax +39 035 606 463



L268U05

**GREENER  
 BY NATURE**





### Korinto - all you could wish for

Compact, easy to use and extraordinarily versatile, the Korinto has all. A result of more than forty years of experience at Necta, the Korinto is a super-automatic hot beverage dispenser with highest quality components and sturdy materials that allow it to support heavy workloads.

The refined design and particularly user friendly interface make the Korinto ideal for any environment, such as hotels, B&B, club houses, restaurants, etc. Special versions have been developed for bars and coffee shops, due to its ability to dispense two cups of coffee at the same time.

Part of a long tradition of top of the range food and beverages solutions for N&W, Korinto possesses advanced technology that ensures exceptional performance, excellent drink quality and ease of operation.



### Superior technology to satisfy every need

If it's style and sophistication you're looking for, Korinto has the answer. Necta has developed, designed and implemented different technology to create a perfect high quality drink for every taste.



### Espresso

Thanks to the patented coffee group, the volumetric doser and the extraction according to the parameters of the best Italian espresso, Korinto offers a unique coffee together with a range of exquisite mixed beverages.



### Fresh Brew

The Sigma Brewer (patented) guarantees very high quality beverages, through the high extraction of the coffee and tea.



### Instant

The mixers produce a first-rate beverage with a good emulsion and perfect crème.



### Simple and stylish Korinto

With a simple and clear display, which guides users in the choice of their preferred beverage, and the large plain selection panel, the Korinto is very simple to use. Its compact dimensions make it easy to position and move, and has a wide selection menu offering up to eight different drinks.



### Easy maintenance and cleaning

The Korinto's cleaning and maintenance system is simplicity itself. The optimisation of the mixer's parts (only three components), the suction of dust through a small built-in drawer, and the dust conveyor make cleaning operations quick and simple. Moreover, the mixers and brewing units are easy to remove by using the green coloured release system.

### Accessories

In order to suit every client's requirements, a complementary range of accessories is available including:

- Super-equipped base cabinet with solid and liquid waste containers plus cups/sugar/stirrers holders
- Payment system module
- Cup holder module
- Cup warmer
- Water filter kit



### Espresso

<b>Drinks delivered ES+1IN</b>	Double espresso Americano Café macchiato Cappuccino Café au lait Café latte Hot water
<b>ES+2IN</b>	Espresso Americano Caffè Latte Cappuccino Caffè Mocha Chocolate Chocomilk Hot Water
<b>Hourly output</b>	70 espresso coffee 60 cappuccinos 100 chocolates 10 litres of hot water
<b>Ingredients capacity</b>	Coffee beans 1.4 kg or 1.0 kg (ES+2IN) Skimmed milk powder 0.75 kg Chocolate 1.5 kg (only ES+2IN version)
<b>Weight</b>	32 kg
<b>Appr. number of coffee's before refilling</b>	150 cups (ES+1IN) 100 cups (ES+2IN)

### Instant

<b>Drinks delivered</b>	Espresso Americano Café au lait Café latte Cappuccino Café mocha Chocolate Hot water
<b>Hourly output</b>	120 cups 80 cappuccinos 100 chocolates 31 litres of hot water
<b>Ingredients capacity</b>	Soluble coffee 0.65 kg Skimmed milk powder 0.75 kg Chocolate 1.8 kg
<b>Weight</b>	30 kg
<b>Appr. number of coffee's before refilling</b>	400 cups

### Fresh Brew

<b>Drinks delivered Coffee version</b>	Filtered black coffee Café au lait Café latte Pot of black coffee Cappuccino Café mocha Chocolate Hot water
<b>Tea version</b>	Espresso Americano Café au lait Cappuccino Black leaf tea Stronger black leaf tea White leaf tea Hot water
<b>Hourly output</b>	150 cups 80 cappuccinos 100 chocolates 31 litres of hot water
<b>Ingredients capacity</b>	Ground coffee 0.9 kg Freshbrew tea 1.0 kg Soluble coffee 0.65 kg Skimmed milk powder 0.75 kg Chocolate 1.8 kg
<b>Weight</b>	35 kg
<b>Appr. number of coffee's before refilling</b>	100 cups

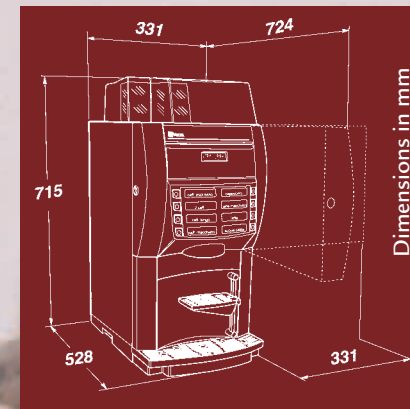

Espresso Version



Instant Version

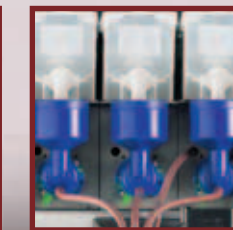

Fresh Brew Version



**GREENER BY NATURE**

- We were first in the business to achieve ISO 14001
- We lead the way with lean, green production processes
- Avex 2007 Awards Best Sustainability award
- Vending Paris 2008 Awards Best Sustainable Development & the Environment
- We apply Life Cycle Product Design
- We adhere to a stringent Environmental Management System
- We adopt product Life Cycle Assessment
- We're proud to be a member of the EMP committee

